



# UEE

Unit Electrical Engineering Ltd.

**POWER UP!**

Custom-built solutions and Field Service for Mining,  
Renewable Energy, Transportation, and Industrial + Commercial.

Power Up! with Unit Electrical Engineering Ltd.

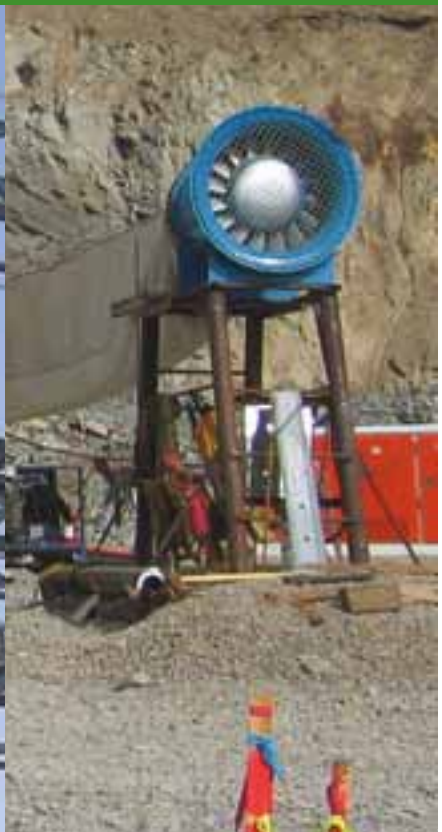



Unit Electrical Engineering Ltd.  
POWER UP!

# An Electrical Solutions Company

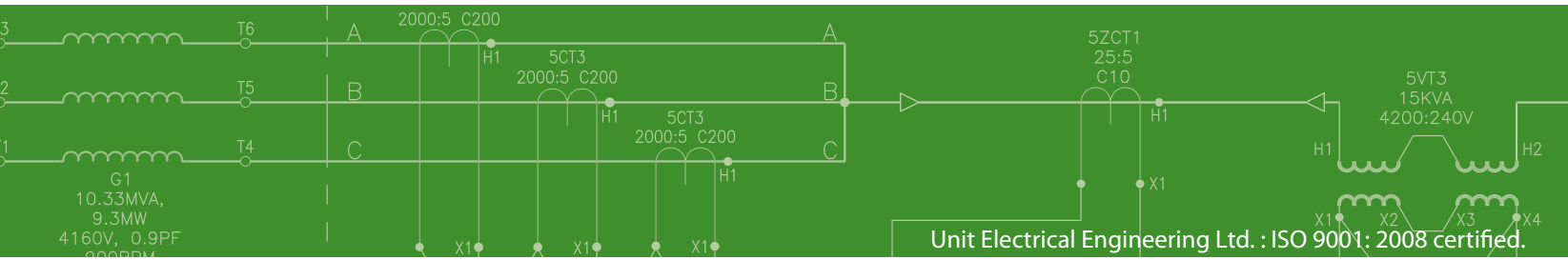

Latitude = 49.3387, Longitude = -119.5683 Lat = 49 degrees, 20.3 minutes North Long = 119 degrees, 34.1 minutes West

British Columbia Office: 1406 Maple Street  
Okanagan Falls, BC  
V0H 1R2, Canada

tel: (250) 497-5254  
fax: (250) 497-6061  
gen. email: general1@uee.com

RFQ email: rfq@uee.com  
www.uee.com



# Modular Labs + Assay Equipment

## Sample Screener Device

The sample screener is a compressed-air operated, mechanical vibration device that screens assay samples for testing. It is constructed out of high-quality stainless-steel, and has a funnel that directs samples through a funnel. Screening action is accomplished by an air-piston powered vibration unit.

Screener includes sample drawers, air filter, oiler, regulator, and vibration control valve.



## Dust Exhaust Hoods

Dust exhaust hoods are designed and manufactured to fit customer needs. They are typically made from 11-gauge steel, but can also be supplied in stainless-steel or with a special chemical-resistant epoxy coating. Dust hoods can also be configured with lights, compressed-air fittings and regulators as well as other tools and options.



## Workbenches, Shelving, and Storage

UEE can design and manufacture custom work surfaces, shelving, and storage out of a variety of materials and with a number of surfaces suited for the harsh conditions found in a mine laboratory.



# UEE Mining Services



*Open Pit Copper Mine, Canada – 13.8kV Mobile Substations*



## Mission Statement

To be recognized as an industry leader in the manufacture and design of electrical power, distribution and control equipment.

## Corporate Statement

Unit Electrical Engineering Ltd (UEE) is a respected electrical manufacturing company with a proven track record of meeting and exceeding the equipment demands of its customers. Combined with the organization's excellent manufacturing abilities is a significant level of engineering depth and expertise, which allows UEE to provide engineering services that complement and continuously improve its products, while supporting its commitment to its customers.

*Underground Gold Mine, Russia – Moveable Substations*



*Surface Coal Mine, China – Substations*



*Open Pit Copper Mine, Canada – Couplers & PLC Systems*



# An Electrical Solutions Company

## Why UEE?

Professional engineering, custom designs and standard product offerings driven by global experience and backed by supportive, knowledgeable project management and comprehensive field service means UEE is your one-stop-shop for complete electrical solutions.

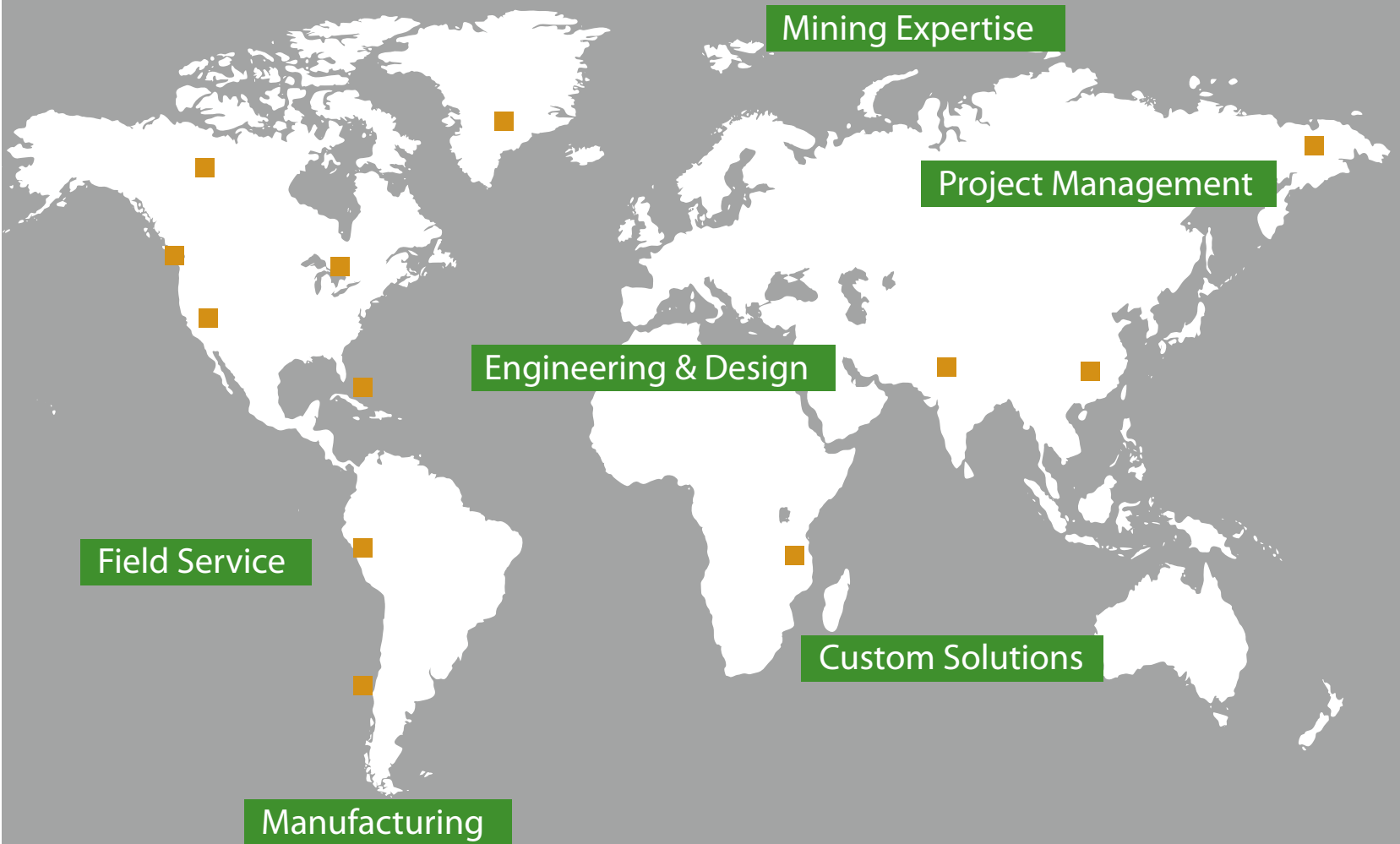

# An Electrical Solutions Company

## Assay Equipment

### Batch Filter Press

The batch filter press utilizes a five-ton screw-jack mechanism to ensure a pressure-tight sample pressing chamber. The standard stainless-steel chamber has a capacity of 22 liters, and is designed to swing away from the sample deposit area. A combination of specialty filter paper and cloth is used to contain the pressed slurry samples.



### Sample Blender

The sample blender is designed to handle dry or nearly dry powders, minerals, or solid mixtures. It uses two 15 liter, stainless-steel conical blending chambers that are manipulated with an end-over-end rotating motion to thoroughly blend samples. Sample blenders come complete with dust exhaust hood, work top stand, fluorescent lighting and two sample drawer bins that incorporate two part splitter.



### Sample Drying Ovens

Heavy-duty sample drying ovens are designed specifically for mineral sample preparation. Ovens frames are welded out of high strength steel and panels filled with special high-temperature insulation form the walls. The entire structure can be lifted by a crane using removable lifting lugs.

Oven temperature is monitored by a custom-designed electronic control system that can be pre-programmed for specific requirements or easily set in the field. Temperatures up to 120° Celsius can be reached and the entire system will automatically shut down if the oven gets too hot.

Two-door, four-door, and pass-through oven configurations are available, and custom designs are also possible.



### Rotary Sample Splitter

The rotary sample splitter evenly distributes dry material (from powder to 1/4") without classification into six removable, interlocking 1-liter containers. Sample material is loaded in a 20-liter hopper, which deposits material onto a moving conveyor belt and into collection containers that are mounted on a rotating turn-table. Hopper, containers, turn-table, and table top are all constructed out of stainless-steel. Conveyor belt and turn-table are controlled by independent motor controllers.





## 5 Portable Assay Lab Facilities

The UEE modular system has successfully been applied in the manufacture of portable assay laboratory facilities. Working in partnership with a highly-qualified and extremely experienced analytical laboratory consultant, UEE is able to provide complete assay laboratory solutions from stand-alone assay equipment to complete, turn-key laboratories.

### Modular Laboratories

Leveraging our modular building design, we are able to build durable, practical, and efficient laboratories that are completely self sufficient and perfectly suited to all mining environments.

Laboratories are planned to maximize the efficiency of assay testing, and entire flow from sample preparation to final analysis is taken into consideration and the modules configured accordingly. All analytical equipment can be provided, as well as on site installation and commissioning.

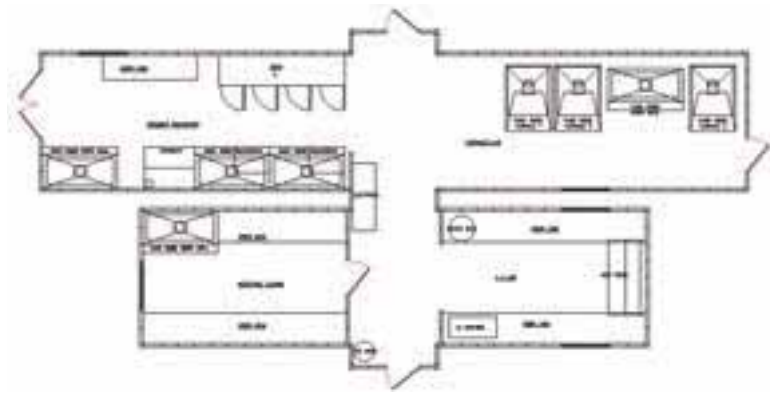

Laboratories come complete with all required environmental support systems, such as HVAC units, dust collection and filtration, air-make-up units, and acid scrubbers. One module is typically used to tie together sample processing modules, and functions as secondary storage and a convenient location to store safety equipment such as eye-wash stations and chemical hose-down showers.



# UEE Mining Services

## What can UEE do for your company?

### Engineering & Design

Engineers and Technologists leverage the latest software, design methodology, and industry-approved practices to turn surface and open-pit mining challenges into effective and efficient solutions.

Our engineering team utilizes 3-D modeling; power-flow, fault, and protection studies; and advanced PLC and SCADA design as it strives to innovate for our mining customers.



### Field Service

We provide comprehensive technical field service including testing, commissioning, maintenance, repair and upgrades for power-system around the globe. Our highly-qualified teams service switchgear, circuit breakers, generators, cables, protective system control devices, and perform Doble power factor and power transformer testing and filling using our self contained mobile oil processing unit.

Deployable in unlimited groups, our knowledgeable service teams handle everything from simple start-ups to geographically and technically challenging projects to minimize downtime and maximize mine productivity.

### Manufacturing

Our manufacturing facilities integrate seamlessly with our engineering and design capabilities resulting in consistent and efficient manufacturing of both standard and custom designs. Extensively trained and highly skilled labourers and journeymen operate the in-house foundry, machine shop, fabrication and electrical departments of our 38k+ sq/ft facility.

As an ISO 9001: 2008 certified organization with equipment meeting the latest CSA and regulatory mining standards, our manufacturing processes and methods reflect our ongoing commitment to quality and safety in all aspects of our manufacturing phases.





# An Electrical Solutions Company

## UEE + The Mining Industry

UEE supplies completely engineered, customizable electrical systems to mines all over the globe. From substations, e-houses, trailing cable couplers, laboratories and pit de-watering feeders, to power analysis, protection studies, and on-site service, UEE offers the complete electrical mining solution.



## Custom Solutions

Unconstrained by technical or commercial limitations, UEE designs and manufactures mining power solutions specifically suited to unique and challenging customer requirements. Rarely starting from scratch, UEE's devoted electrical and mechanical professionals leverage an extensive portfolio of proven power sub-systems to design custom mining power solutions that exceed requirements and deliver on time.

Our ability to take project specific requirements and provide custom solutions where needed, ensures the end product meets the most onerous mining demands.



## Project Management

UEE coordinates all its projects from initial proposal to final commissioning through an experienced team of project management professionals, providing customers with a convenient single point of contact for all technical, commercial, and logistic communication.

UEE's dynamic project management structure readily adapts as projects transition from design to manufacture and final delivery. Effectively working with or without consulting firms, UEE's project management structure allows customers the freedom to choose a hands-on approach if they prefer complete control or a turn-key delivery if required.

From consultants to end users, our knowledgeable and reliable project team provides superior customer support while meeting all project requirements.



# An Electrical Solutions Company

- Military
  - hospitals
  - offices
  - labs
  - test facilities
  - equipment repair facility
  - underground bunkers
- Utility Sectors
  - power distribution
  - power conditioning buildings
  - kiosks
  - temporary maintenance or emergency substations
  - motor control centers.
- Construction
  - mobile/portable power generators
  - power distribution.

# The UEE Modular System

- Computer Systems
  - SCADA
  - HMI
  - PLC
- HVAC
  - heating
  - venting
  - air-conditioning
  - dust collection
- Power Generation
- Other Equipment
  - office furniture systems
  - computer network wiring
  - dropped ceilings
  - operator cabins



## Possible Applications

Although originally designed for the mining industry, our durable, flexible modular system is well suited for all industries:

- Mining
  - portable/mobile substations
  - switch houses
  - power gen-sets
  - power distribution rooms
  - crusher control
  - pump control stations
  - motor control centers
  - assay laboratory centers
  - automation control
  - mine-depressurization buildings
  - fuel-pump stations.
- Oil & Gas
  - mobile/portable power generation stations
  - power distribution.
- Laboratory
  - mineral assay testing & analysis
  - field medical laboratories
  - environmental testing facilities.





# UEE Mining Services



## Surface Mining: Design and Manufacturing Solutions

UEE has been involved in the Mining Industry since our inception, innovating and engineering solutions to increase mine productivity, power distribution and mobility. The UEE Modular System, for example, originally designed and engineered by our team and now in widespread use, provides a versatile, mobile, cost-effective fully engineered solution for all of the electrical equipment a mine requires for productive functioning.

With the products our Mining customers were asking us to engineer and build – substations, switch houses, generator stations – we recognized the need for modular, stackable, standardized steel portable enclosures. Customizable to meet the unique geographical needs of any mine location, the UEE Modular System has become the “killer app” of the mining industry.

## Underground Mining: Design and Manufacturing

UEE's range of and ability to design equipment ensures that we can supply electrical equipment used in underground mining. From gold, diamond, copper or other base metals, UEE supplies underground mining equipment to major mining companies, both domestically and internationally.

Whether it be underground moveable substations, fixed underground substations, LV distribution equipment or starters, UEE has a proven track record in underground mining.

*Pit Dewatering Substations*



*Protection Control Buildings*



*Trailing Cable Couplers*



# An Electrical Solutions Company



## Team

Power Up! with our dedicated, internationally experienced team of engineering professionals.

UEE maintains a design and manufacturing team of over 100 skilled engineers, technologists, technicians and trades personnel to meet the exacting demands of our clients in the Mining industry. UEE engineers support your project through the custom design of complete electrical packages, including system programming, site testing and commissioning of equipment and process systems.

For Consulting Engineering Companies, our teams deliver value-added services, from site analysis to providing onsite mechanical and electrical support personnel.

To help you Power Up! your overseas Mining project, our international sales representatives are here to simplify your power procurement process, and get your project up and running.

## Examples of Mining Clients across the Globe

BHP Billiton • DeBeers • Kinross • NewGold • Centerra Gold • Shenhua Group Corp. Ltd • Teck • Barrick Gold Corporation • Wabush Mines • Iron Ore Canada • Grande Cache Coal Corp. • Rio Tinto • Glamis Gold Ltd. • Suncor Energy • Shell Canada

*Substations – Mobile*



*Switch Cabinets*



*Electrical Rooms*



# An Electrical Solutions Company

## Extreme Climates

The UEE modular units are designed and manufactured to withstand extreme climatic conditions. They are well insulated with rigid foam insulation, or fireproof rock-wool insulation if required.

If heat dissipation is required, as for substations or gen-sets, automated ventilation is design into the building. HVAC or simple heating schemes are also available.



## Durable Construction

UEE combines formed steel panels and structural steel beams to create buildings that are exceedingly robust and durable using a proprietary construction technique.

All steel components are painted or powder-coated with industrial grade finishes to prevent corrosion, and assembled with rivets for resilience and durability. All seams are sealed with industrial sealant to ensure a water and air-tight finished product.



## Custom-Built

Suitable for an incredibly diverse range of applications, our modular structures can be custom-designed to meet any customer need. Modular structures can be designed and built to incorporate some or all of the following systems:

- Electrical
  - interior and exterior lights
  - equipment outlets
  - motor control centers
  - alarm and control systems
- Plumbing
  - laboratory needs
  - washrooms
  - lunchrooms
- Laboratory Equipment
  - fire assay
  - sample preparation
  - met lab
  - wet lab
  - medical
  - environmental





## 4 Modular Systems

The UEE modular system was developed as an alternative to standard shipping containers that have been used to house electrical equipment in the past. Responding to customer comments, UEE designed a system to build incredibly durable, extremely configurable, and completely climate-proof enclosures suitable for the harsh environments encountered in mines. This system leverages a frame and panel technique capable of providing versatile construction solutions for modular steel enclosures and buildings. Enclosure modules manufactured using this system have now been engineered to withstand diverse applications and extreme environments.

Our modular system can be sized for a diverse range of applications in various commercial, industrial, and utility sectors. Typical units are built with a 11'2" width and 10' height for ease of transportation to site via highway transport, but other sizes are available (limited only by shipping logistics). The construction of our modular buildings is complete at our factory, so on-site setup and labour costs are minimized.

UEE buildings can be designed for pad-mount, skid-mount, or trailer-mount applications. If space is limited, these buildings can be stacked up to three modules high.

### Unlimited Potential

UEE modular units are highly configurable, and can be easily expanded and modified once they are in service.

A perfect example of the flexibility of our modular design is an assay laboratory facility. Shown here complete, this laboratory was designed to operate initially as a temporary MCC and then as a complete laboratory. After it had been operating for a year, the second phase arrived at site, the complete laboratory was up and running within hours.



### Structurally Engineered

Our modular buildings are engineered to provide structural integrity and resistance to elements. In addition, they can be hoisted without spreader bars (structures up to 25 feet).

In addition to resisting the stresses of hoisting, our modular structures withstand extreme environmental forces:

- Wind – maximum design wind capacity is limitless (Governing - Max Design Wind Velocity = 90mph)
- Seismic – buildings are sufficiently strong to resist the worst seismic loading listed in IBC2000, however buildings must have adequate anchors to foundations. (Governing – Seismic Zone 4)
- Roof Load (Snow) – max allowable snow load = 100 PSF (greater load available)



# An Electrical Solutions Company

## UEE Products + Services

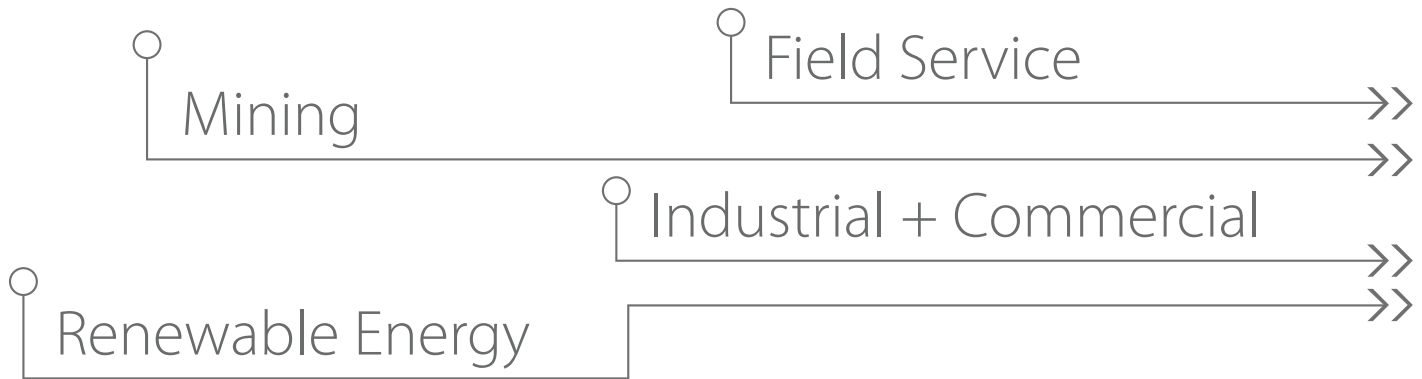

### Modular Buildings

Labs  
E-Houses  
Substations  
Operator's Cabins  
Protection & Control

### Lab Equipment

Assay Labs  
Sample Preparation  
Metallurgical Labs  
Cupellation  
Acid Labs  
Sample Drying Ovens  
Sample Filter Presses  
Dust Hoods

### Power Generation

Diesel Gensets  
Automated Transfer Schemes  
Backup Power  
Protection Relay Systems

### Substations

Main  
Portable  
Underground  
Pit Substations  
Utility  
Traction

### Motor Controllers

Custom MCCs  
PDCs  
480/600 Volt Motor Starters  
Jumbo/Bolter Starters

### Electrical Switchgear

Metal-Enclosed  
Metal-Clad  
Arc Resistant  
Indoor + Outdoor  
MV + HV

### Renewable Energy

Hydroelectric  
Wind  
Biomass

### Trailing Cable

1 kV Couplers  
8 kV Couplers  
15 kV Couplers  
25 kV Couplers  
Cable Handling  
Cable Reel Handlers  
Cable Repair Stations  
Cable Reel Supplies

### Industrial Control

Custom Panel Design  
PLC Programming  
HMI Design  
SCADA Engineering  
Network Systems

### Field Service

Power Transformer  
Vacuum Oil Purification (VOP)  
Substation  
Generator  
Switchgear  
Protection & Control Systems  
Circuit Breaker  
Coordination & Ground Studies



## Reliability and Safety

Safety and convenience: two high-voltage power distribution concepts that no longer cause contradiction. It was once thought that safety could only be achieved with permanent, fixed, and inconvenient connections, especially in the 15 to 25 kV range, but that is no longer the case. By properly utilizing the UEE quick-connect coupler system, one can have unsurpassed reliability and safety without compromising quick-connect convenience.

Below is an example of how UEE quick-connect connectors can be used to improve the efficiency and safety of a mine site.

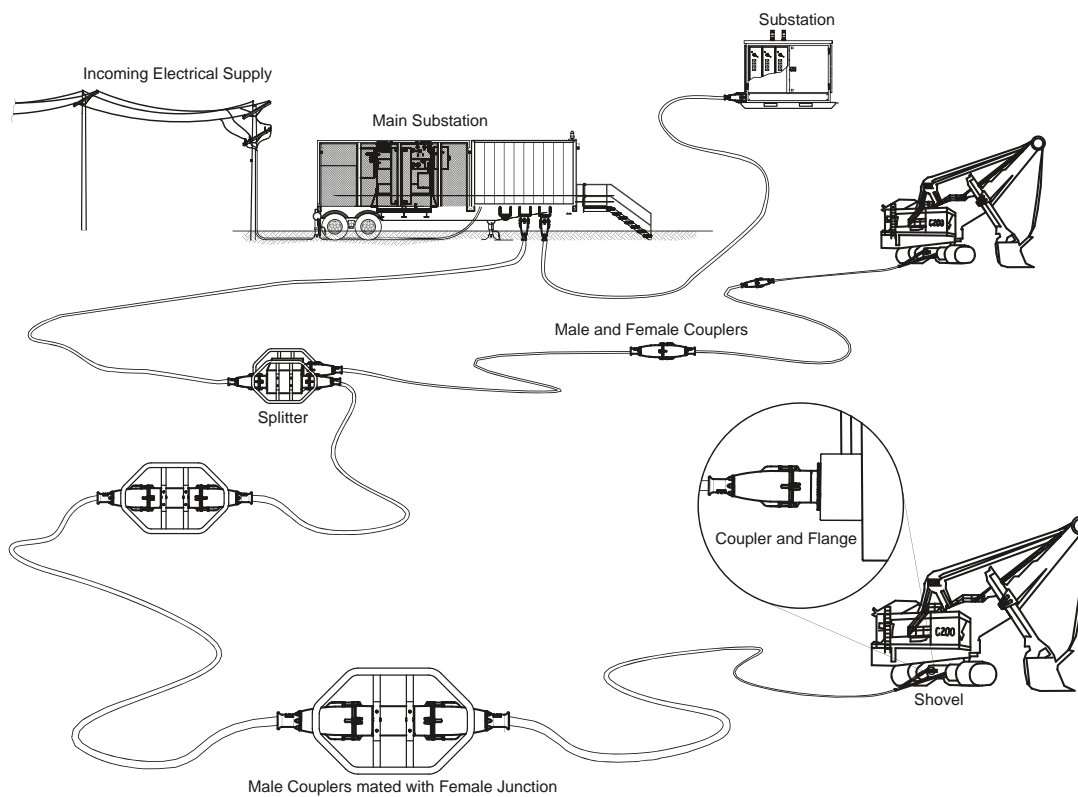

The UEE quick-connect connector system is perfect for reliably connecting high-voltage supply feeds to shovels, drilling rigs, and other open-pit and underground mining machines. They can also be used to connect low-voltage motors, fans, pumps, or other piece of mobile electrical equipment.

Once cables are terminated with UEE couplers, a truly *plug-and-play* power distribution system is possible, virtually eliminating downtime when damaged cables need to be replaced or equipment has to be redeployed.



# An Electrical Solutions Company

- UEE designs HMI applications, networking and SCADA systems to provide an accurate, reliable and professional looking interface to the end-user.
- Pre-engineered UEE software packages for hydroelectric generating stations provide a fast and proven solution to bring your plant on-line sooner and minimize downtime.

## Power Systems and Protective Relaying

UEE designs and fabricates protection panels for any power system.

- Whether it's replacing an obsolete system or construction of a new facility, UEE has the experience to design the right protective relaying system that keeps your equipment safe and your power on. Power Flow Analysis, Fault Analysis and Protection Coordination Studies are just some of the services available through the UEE engineering department.
- UEE provides engineered protection settings for any make and model of protection relays.
- From a transmission-line feeder to a complex generating station, UEE can design and fabricate protection panels for any project.

# Power Distribution + Control Equipment

Mobile gen-sets are also available, as shown to the left. This mobile 1600 kW, 4160 Volt generating package was designed and fabricated by UEE to provide automated emergency power to a pit dewatering system, but also has the ability to provide energy to mobile mining equipment such as shovels and drills.

## Pump Control Stations

UEE designs and manufactures two standard types of pump control equipment: pump control buildings and pump control stations.

Pump control buildings are *walk-in* structures used to power and control pump house motors and pumps that usually pump recycled water from tailing dams to process areas of a mill.



Pump control stations are similar to underground substations and utilize the UEE modular, *plug-in* feeder boxes. Feeder boxes contain motor and pump controls and can be easily and quickly replaced for future expansion. They are manufactured from satin-coat steel and protected with a polyester powder-coat paint for durability.



UEE pump control stations and buildings can be supplied with UEE quick-connect couplers for safe and reliable hookups.



## Power Controllers (UPC boxes)

UEE designs and manufactures compact electrical equipment used in various applications.

UPC600V is a power controller at 600 Volts and is typically used in underground mining as a stand-alone unit or as part of a power distribution system supplying power to underground machinery. It can be used to start fans, power pumps or motors, control conveyor systems, or process controls. The enclosure is made out of stainless steel, and has a NEMA 4 rating.

UPC5kV is a skid-mounted, cabinet-style enclosure that is also used as a power distribution unit in underground mining. Typically rated at 5,000 or 8,000 Volts, custom rating are also available.

## PLC, HMI and SCADA Panels and Programming

UEE provides complete turnkey solutions for a wide range of automation projects.

- UEE designs and manufactures control panels for any model of Programmable Logic Controllers (PLC's) and Human Machine Interfaces (HMI's).
- From a simple pump station to an entire mining site, UEE Automation specialists can design and commission both the hardware and software for your project.
- UEE Automation Specialists and Engineers will work with customers to develop the most efficient control algorithms for any industrial process, and can implement them in any PLC language.

# An Electrical Solutions Company

## Safety

When designing our coupler products, we were guided by the very stringent CSA standard CAN/CSA-M421, Use of Electricity in Mines that defines minimum requirements for electrical equipment used in Canadian mines. In particular, our coupler products meet the standard's specific requirements for quick-connect cable couplers by incorporating the following features:

- a mechanical fastening arrangement to join the connector to its cable with a tensile strength greater than that of the cable;
- strain relief devices suitable for the intended portable cable;
- a means to seal out moisture;
- a means to mechanically lock the coupler;
- a conductor arrangement with:
  - ground conductors make before and break after the phase conductors;
  - a ground-check circuit that makes after and breaks before the phase conductors;
- provisions for ground-fault protection and ground-conductor monitoring at the supply source.

## Conductor Arrangement

The conductor arrangement ensures that UEE's quick-connect couplers are completely safe to use in the field, even when connecting high-voltage systems. Using a suitable ground-check monitoring system, power cannot be turned on until couplers are completely connected so there is absolutely no possibility that workers can be exposed to live conductors and dangerous currents.

If a coupler in a live circuit is disconnected, power shutdown at the source is triggered as soon as the ground-check circuit is opened. This happens within a few millimeters of movement, long before any of the conductors are accessible. At this point the phase and ground conductors remain in contact so current can continue to flow while the power supply shuts off. The phase conductors disconnect next, and the ground circuit is the last to open so any residual fault current has a path to ground until the coupler is completely apart.

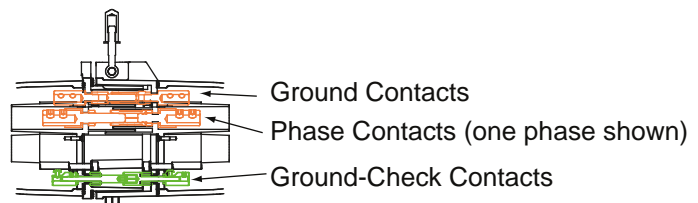
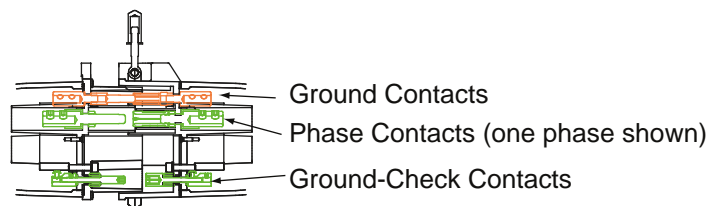

## Inter-Phase Ground Shield

To increase the safety and reliability of our medium- to high-voltage couplers (8 kV to 25 kV), we have incorporated a complete phase isolating ground shield system to eliminate phase-to-phase faults. With the inter-phase ground shield, any fault current passes directly to ground, greatly reducing catastrophic phase-to-phase failures.

# Trailing Cable Couplers

## Conducting Parts

All major electrical conductors are manufactured out of 99.9% pure copper or high-quality copper alloy (brass). Pure copper is used in parts that require exceptional electrical and thermal traits and are not limited by copper's relatively soft physical characteristics. Conductor parts that require greater mechanical resilience, such as sockets and collets, are made out of high-quality brass. All major electrical conductors are electroplated with a silver coating to maximize conductivity and minimize friction so electrical resistance is controlled and couplers are easy to connect and disconnect.

Where extra contact force is required, as in socket parts and assemblies, non-magnetic, stainless-steel spring bands are used to increase the contact pressure without creating the conditions that contribute to harmful induced currents.

Male, pin-type conductors have stepped profiles to ease insertion into female, socket-type conductors. Non-collet conductors utilize brass set-screws to eliminate non-ideal thermal effects and they also have fine-pitch threads to limit loosening.

## Collet System

Select UEE couplers utilize our patented collet phase wire securing system that eliminates set-screws altogether.

Rather than using a set-screw or a messy solder type connection, our collet system uniformly and securely squeezes phase wires for a simple, reliable, low resistance connection.

To use the collet system, phase wire is inserted into the hole of the collet and a bolt pulls the collet into the phase conductor. As the collet is pulled into the phase conductor, the phase wire is squeezed as the collet taper slide against the phase conductor taper.

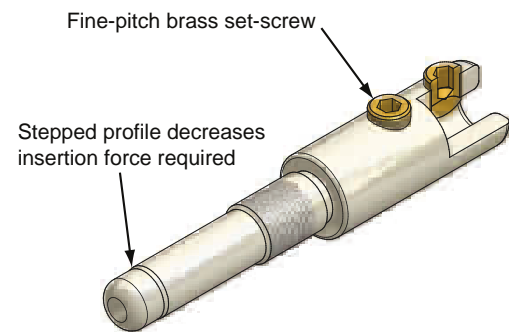

Silver-Plated Copper Conductor

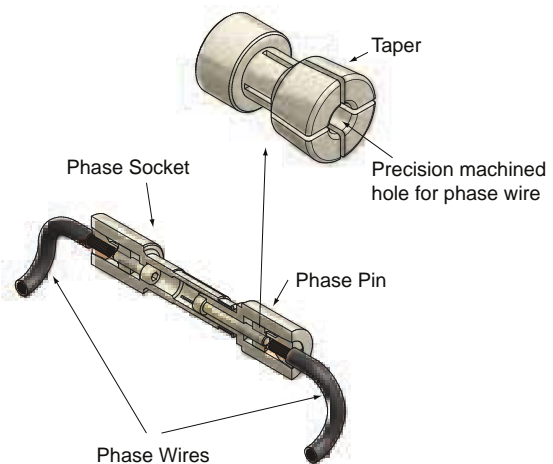



# An Electrical Solutions Company

Configurations can include:

- Power capacity up to 1500 kVA (others on request)
- Up to 15 kV primary voltage
- 480 or 600 Volt secondary voltage (others on request)
- Low-profile and/or split-enclosure
- Fork lift attachments
- Power metering
- Contactor remote control
- Ground-fault and ground-check monitoring
- Overload and overcurrent protection
- Ammeter and voltmeter



## Motor Control Centers and Power Distribution Centers

UEE's modular buildings are ideal for housing MCCs and PDCs for low, medium, and high voltage systems that are self-contained, climate-proof. MCCs and PDCs can be supplied to UEE, or UEE can source them using customer specifications and needs.



UEE can also provide PLC/HMI control panels, computer systems, and programming to meet specific customer requirements. In addition, buildings can be configured with station service, lighting, HVAC systems, electrical receptacles, and complete alarm systems.



Every unit is designed, manufactured, and tested at the UEE facilities prior to being shipped to site. The modular construction system reduces on-site construction time and costs.

## Power Generating Centers (Gen-Sets)

Modular power generating stations can form an integral part of an existing building or can be mounted on a trailer or skid if mobility is required.

These units include forced air ventilation, fuel storage, and complete protection and control systems for the generator and its loads. Customers can specify engine type, generator, electrical characteristics, or leave the fine details to UEE. In addition, if multiple output voltages are needed, a transformer can be supplied and the UEE quick-connect coupler system can be used for convenient hookups.



# Power Distribution + Control Equipment

## Electrical Substations — Moveable

One of UEE's specialties, mobile/portable substations are very flexible and convenient. They are predominantly used in open-pit mining operations to supply electrical power to moveable equipment such as shovels, drills, and pumps. They are also favorably deployed in the utility sector, oil and gas operations, and for use in remote or temporary locations.

Moveable substations can be assembled on a flat deck trailer or a steel skid. For a completely self-contained substation, a heated and ventilated switch house mounted on a trailer with a main transformer can be delivered to any mine site for immediate installation.

Moveable substations can be configured with any of the following features:

- Trailer or skid-mount for mobility
- Insulated switch house for extreme climates
- UEE quick-connect couplers for convenient connections
- Completely custom design
- Modular assembly with expansion potential



## Electrical Substations — Underground

These compact substations are designed specifically for underground hard rock mines where harsh environment and limited space are major concerns. They come complete with a transformer that is protected from overcurrent by an incoming load break switch and ground-fault, ground-check monitor system.

The substation's secondary side features a fully modular, field configurable distribution and motor control center. Individual enclosures can be configured with moulded case circuit breakers, vacuum contactors, overload protection, and ground-fault/ground-check monitoring to protect and control mobile electrical equipment. The modular nature of the individual enclosures that can readily be removed from the substation enables quick and easy repair and maintenance in the comfort of a workshop rather than on site.

Underground substations are compact, rigid, and their skid mounted enclosure can be dragged around the mine.



# An Electrical Solutions Company

## Bodies and Fittings

All UEE coupler bodies and fittings are manufactured out of high-quality aluminum alloy that is cast in our non-ferrous foundry and machined on one of our CNC machines. This method results in bodies and fittings that are light, durable, and economical.

Aluminum parts will not rust, but they can be coated with a rugged polyester powder-coat finish for identification purposes, and if a more durable low-voltage coupler product is required, our 160 and 240 amp 1100 Volt coupler bodies and fittings can be manufactured out of bronze.

UEE entrance fittings provide an entirely waterproof cable-to-coupler interface that also mechanically secures the coupler to the cable. Entrance fittings seals use gaskets and hose-clamps or compression grommets. All entrance fittings are customized for the specific characteristics of the customer's cable.

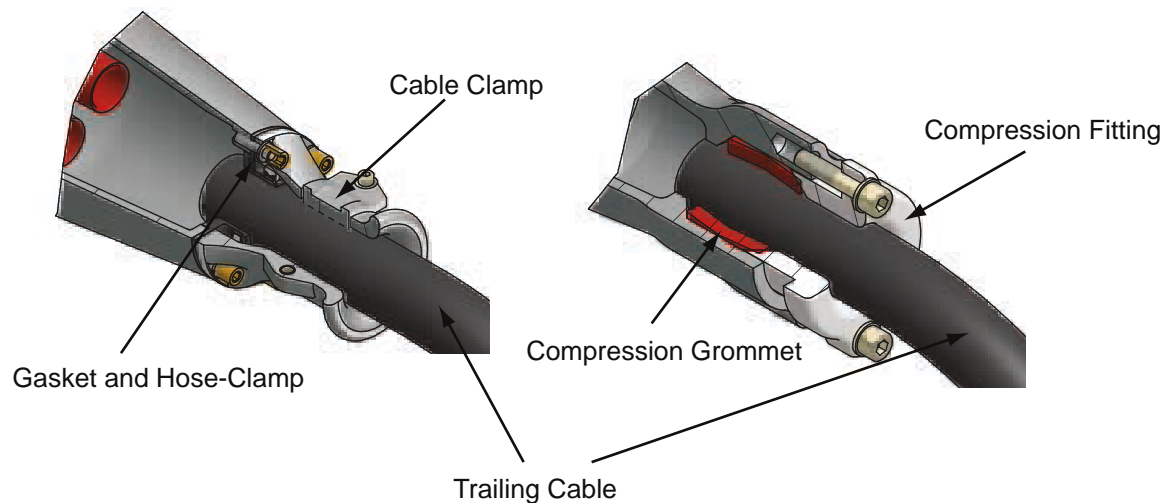

To ensure that all coupler connections meet the mechanical locking requirement of CAN/CSA-M421, stainless-steel eyebolts and brass nuts secure parts while in use. The eye-bolt securing scheme is simple, easy to use, and is not as sensitive to dirt contamination when compared to couplers that rely on threaded bodies for their mechanical connection.

Every coupler ships with a convenient cover to protect contacts and insulators from dirt and physical damage.

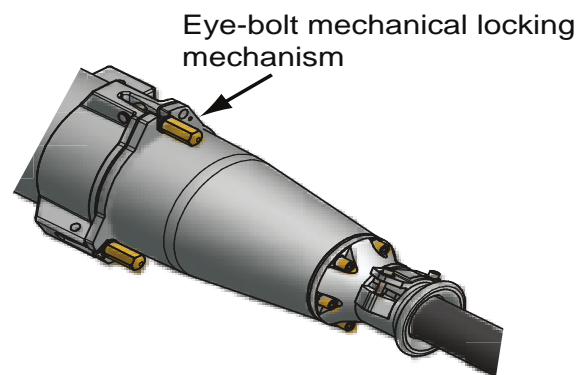

# Trailing Cable Couplers

## Users of UEE Couplers

Unit Electrical Engineering Ltd. coupler systems are used around the world in gold mines, open-pit coal mines, for oil and gas extraction projects, at high-altitude mineral deposits, in microtunneling projects, and for various industrial electrical distribution facilities.

### North America

Huckleberry Mines Ltd. (Canada): copper/molybdenum mine; 1 kV and 8 kV.

Iron Ore Company (Canada): iron ore operation; 1 kV, 8 kV, and 15 kV.

Syncrude (Canada): oil and gas; 1 kV and 8 kV.

James W Fowler Co. (USA): industrial projects; 1 kV.

Albian Sands Energy Inc. (Canada): oil sands; 1 kV, 8 kV, and 15 kV.

Wabush Iron Company (Canada): iron ore operation; 1 kV and 8kV.

New Gold Mine (Canada): gold mine; 1 kV.

Grande Cache Coal Corporation (Canada): coal mine; 1 kV and 22 kV.

Wolverine Coal Ltd. (Canada): coal mine; 1 kV and 8 kV.

BHP Billiton Diamonds Inc. (Canada): diamond mine; 1 kV.

Suncor Energy Inc. (Canada): oil and gas; 1 kV, 8 kV, and 15 kV.

Mountain Industrial Power (USA): microtunneling; 1 kV.

Northwest Boring Company Ltd. (USA): microtunneling; 1 kV.

Mount Polley Mining Corporation (Canada): copper/gold mine; 8 kV.

Potash Corporation (Canada): potash extraction; 8 kV.

Tech Electric (USA): various mining operations; 8 kV.

Bucyrus International Inc. (USA): mining equipment; 8 kV.

Elk Valley Coal Corporation (Canada): coal mining; 8 kV.

Highland Valley Copper (Canada): copper mine; 8 kV.

Canadian Natural Resources Ltd. (Canada): oil sands; 15 kV.

P & H Mining Equipment (USA): mining equipment; 15 kV.

### South and Central America

Eecol Electric (Chile, Peru, and Argentina): various mining; 1 kV, 8 kV, 15 kV 25 kV.

Montana Exploradora (Guatemala): gold mine; 1 kV.

Rahco International Inc. (Mexico): gold mine; 8 kV.

Tecnica Universal S.A. (Guatemala): mining equipment; 1 kV.

### Europe and Asia

EastWest Gold Corporation (Russia): Kupol gold mine; 1 kV.

Herrenknecht (Germany): microtunneling; 1 kV.

Kumtor Operating Company (Kyrgyz Republic): gold mine; 1 kV and 8 kV.

Wampfler Pty Ltd. (Australia): iron, gold, and coal mines; 8 kV.

Omai Gold Mines Ltd. (Republic of Suriname): gold mine; 8 kV.

PT Freeport Mining in Indonesia: copper/gold mine; 8 kV.

PT Newmont (Indonesia): copper/gold mine; 8 kV.

Shenhua Zhungeer Energy Co., Ltd. (China): various coal mines; 8 kV and 25 kV.



# An Electrical Solutions Company

## 3 Power Distribution + Control

Unit Electrical Engineering Ltd. designs and manufactures a complete line of power distribution and control equipment from simple switchgear and switchhouses to complete high-voltage distribution systems.



### Electrical Switchgear

UEE manufactures switchgear for industries including mining, commercial, and industrial. Systems up to 38 kV are readily available, and can be housed in standalone enclosures or in a custom modular buildings.

UEE utilizes the highest-quality components, selecting the most appropriate features and economical configurations to produce the best possible solution for every budget. Common components come from:

- ABB
- Siemens
- Allen Bradley
- Toshiba
- Cutler Hammer
- GE
- Joslyn Clark.



### Electrical Switch Houses

UEE switch houses can be designed as *walk-in* or *stand-alone*, and can be mounted on a skid or trailer for mobility. Switch houses can be configured exactly to customer specifications, including HVAC systems for extreme weather conditions, forklift attachments for easy movement, and UEE quick-connect couplers for quick, convenient, and safe connections.



### Substations

#### Substations — Main

UEE designs and installs main substations for industrial applications.

Shown is the 69 kV main substation that UEE designed, built, and installed for Imperial Metal's at its remote Likely, British Columbia Mount Polley mine.

Structural steel parts were fabricated at the UEE facilities, electrical equipment was commissioned, PDC and back-up generator were designed and manufactured by UEE and the complete substation was installed on-site by UEE personnel.



# Trailing Cable Couplers

## Cable Reel Stand

The UEE cable reel stand incorporates a hydraulic jack that makes cable reel elevation quick, safe, and easy. The stands are made of heavy-wall steel tubing that is powder-coat painted for long life.



## Cable Clamp

The UEE cable clamp was designed to assist in elevation of heavy cables in open-pit mine applications. Two clamps at each elevation point eliminates stress in the cable, protecting the ground-check wire from damage.

This clamp can also be used in a variety of other cable management applications.

UEE cable clamps come in four sizes:

- CC-56 - for cable from 47 to 56mm
- CC-66 - for cable from 57 to 66mm
- CC-76 - for cable from 67 to 76mm
- CC-86 - for cable from 77 to 86mm



## Cable Handler Stick

The UEE cable handler stick is designed to help mine personnel manage high-voltage trailing cables. Instead of relying on brute-force, mine personnel can use the ergonomically designed cable handler stick to move cables without the risk of physical injury caused by overexertion.

UEE cable handler sticks come in three sizes:

- HW063 - for cable up to 70mm
- HW064 - for cable up to 88mm
- HW065 - for cable up to 100mm



# An Electrical Solutions Company

## Low-Voltage Cable Coupler System — 1.1 kV

The UEE low-voltage cable coupler system is ideally suited to mine/quarry, oil and gas, marine, tunneling, microtunneling, and other industrial sectors.

In addition to CAN/CSA-M421, UEE low-voltage couplers are CSA approved (certification program defined for connectors up to 600 volts).

### Ratings

- Current: 160, 240, 320 Amperes
- Voltage: 1100 Volts A.C.

### Standards

- CAN/CSA-C22.2 No. 182.1-07, *Plugs, Receptacles, and Cable Connectors of the Pin and Sleeve Type* (CSA tested and approved to 600 Volts, includes enclosure rating of CSA Enclosure Type 6P)

### Options

- Bronze Bodies (160 and 240 Amps)
- Polyester Powder-Coat Paint
- Second Pilot or Control Pin

### Accessories

- Angle Adapter for Electrical Enclosures
- Cable Clamp
- Cable Handler Stick

### Configurations

- Male Coupler
- Female Coupler
- Male Flange
- Female Flange
- Voltage Sensing Test Unit



# Trailing Cable Couplers

## Medium Voltage Coupler System — 8 kV

The UEE medium-voltage cable coupler system is typically used in open-pit mining applications where it reliably and conveniently connects mobile electrical distribution systems and other equipment up to 8 kV.

All 8 kV connectors utilize a ground screen system that directs fault currents to ground, eliminating the potential for phase-to-phase faults. Standard 8 kV products (250 and 400 amps) utilize a one-piece phase and pilot pin insulator manufactured out of a durable, high-tech material that resists cracks that can lead to electrical tracking.

High-altitude version available for use at or below 5,200 meters above sea level (400 Amps).

### Ratings

- Current: 250, 400, 600 Amperes
- Voltage: 8,000 Volts A.C.

### Standards

- Designed to CAN/CSA-M421
- Tested to I.E.E.E. Std 386-2006

### Options

- Polyester Powder-Coated Paint
- Kirk-Key Interlocking adapter
- Pilot Wire connector up to 2/0 wire
- High-Altitude (400 Amps)

### Accessories

- Coupler Lever
- Skid Mounting
- Cable Clamp
- Cable Handler Stick

### Configurations

- Male Coupler
- Female Coupler
- Male Flange
- Female Flange
- Female Junction

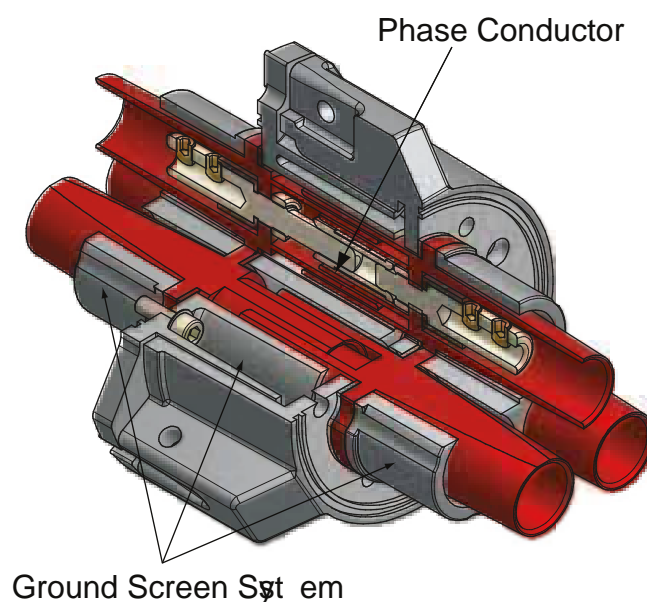



# An Electrical Solutions Company

## Cable Splitter

This skid-mounted piece of equipment incorporates three cable flanges to provide one incoming supply and two outgoing feeds. Splitters include a ground-check circuit multiplexor to ensure that all feeds will safely trip the supply breaker if the ground-check circuit is broken.

Splitter can be supplied with a special termination cover to allow the use of only one feeder.

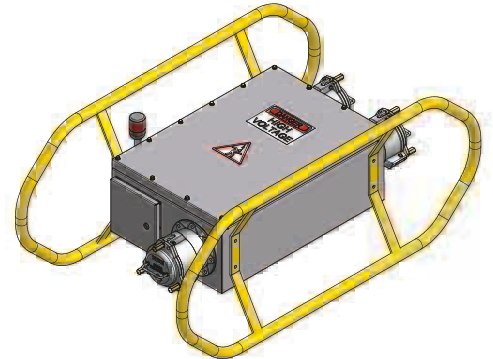

8 kV Splitter

## Cable Repair Station

This skid or trailer-mounted station functions as a complete mobile cable repair facility that can be plugging directly into a pit power distribution system.

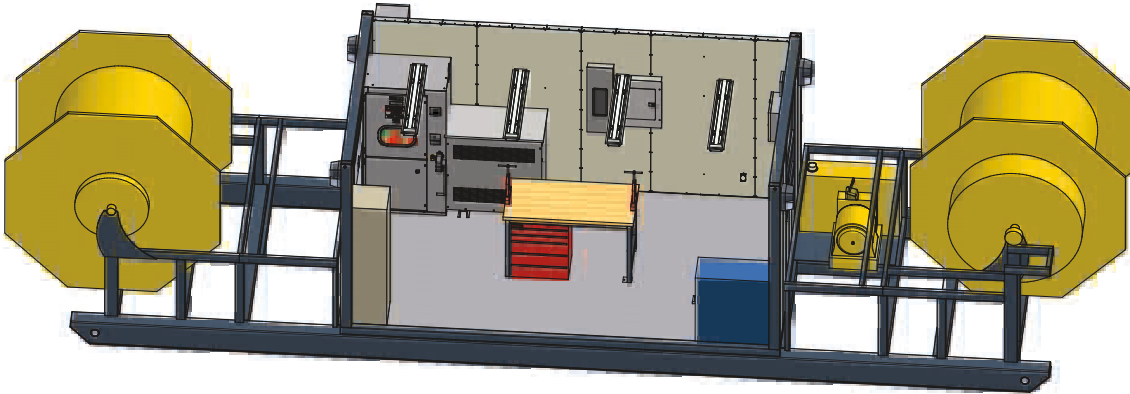

The enclosure is a UEE modular building that can be built to customer's specifications. Inside the enclosure is a safe, fully insulated environment for cable repair personnel. The station is fully equipped with power distribution, cable repair facilities, and tool storage. For harsh climates, it can be equipped with HVAC units to provide heating and cooling to cable repair personnel.

The internal electrical service provides power for heat, lights, and repair equipment. Cable reels are electrically driven and PLC controlled, and optional level winders can be included to manage cable spooling. Cable reels can be supplied with the cable repair station, and for maximum convenience they can be equipped with internal slip rings and loaded with automated reel jacks.



# Trailing Cable Couplers

## High-Voltage Coupler System — 25 kV

The UEE high-voltage cable coupler system is typically used for to reliably and conveniently connects high-voltage electrical distribution systems in industrial settings.

The 25 kV connectors utilize a ground screen system that directs fault currents to ground, eliminating the potential for phase-to-phase faults. The ground screen system uses a special conductive coating that is applied to individual Acetron® phase insulators.

The 25 kV insulation system does not rely on an air-gap for its insulation rating, so this product does not have to be de-rated when used in high-altitude settings.

### Ratings

- Current: 440, 600 Amperes
- Voltage: 25, 000 Volts A.C.
- High-Altitude (does not have to be de-rated)

### Standards

- Designed to CAN/CSA-M421
- Tested to I.E.E.E. Std 386-2006

### Options

- Kirk-Key Interlocking adapter
- Pilot Wire connector up to 2/0 wire

### Accessories

- Skid Mounting
- Cable Clamp
- Cable Handler Stick

### Configurations

- Male Coupler
- Female Flange
- Female Junction

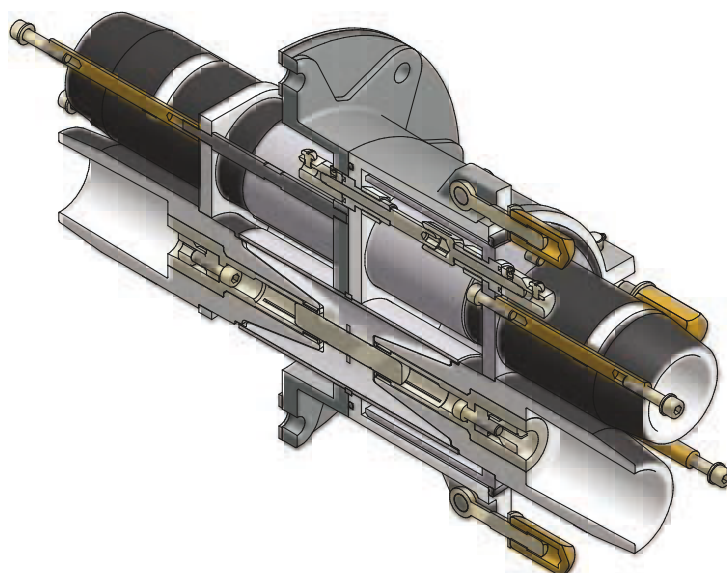

# An Electrical Solutions Company

## High-Voltage Coupler System — 15 kV

The UEE high-voltage cable coupler system is typically used in open-pit mining applications where it reliably and conveniently connects shovels, electrical distribution systems and other equipment up to 15 kV.

The 15 kV connectors utilize a ground screen system that directs fault currents to ground, eliminating the potential for phase-to-phase faults. The ground screen system utilizes a special conductive coating that is applied to individual Fortron® phase insulators.

### Ratings

- Current: 440 Amperes
- Voltage: 15,000 Volts A.C.

### Standards

- Designed to CAN/CSA-M421
- Tested to I.E.E.E. Std 386-2006

### Options

- Kirk-Key Interlocking adapter
- Pilot Wire connector up to 2/0 wire

### Accessories

- Skid Mounting
- Cable Clamp
- Cable Handler Stick

### Configurations

- Male Coupler
- Female Coupler
- Female Flange
- Female Junction

